

# SCI AKY INC.

# EBAM<sup>®</sup> 53

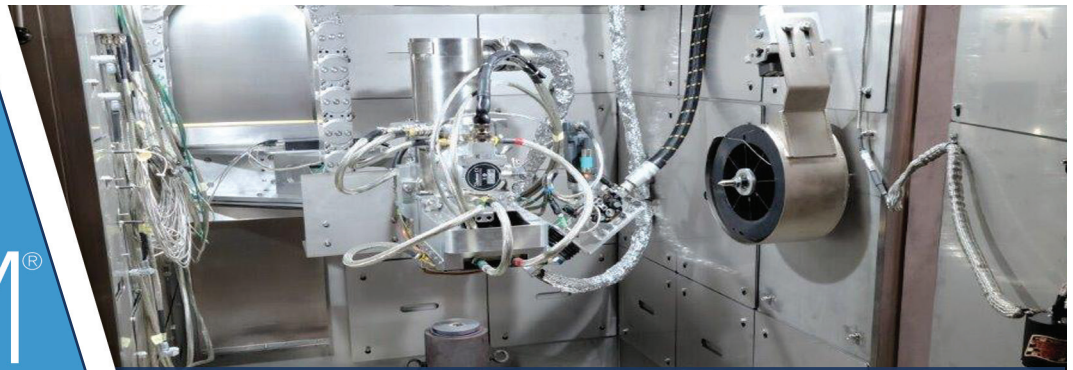

EBAM - The only large-scale metal 3-D printing system in the world with qualified applications for land, sea, air, and space.

▶ **SCI AKY'S EBAM PROCESS PROVIDES HIGH DEPOSITION RATES FOR LARGE-SCALE PARTS.**

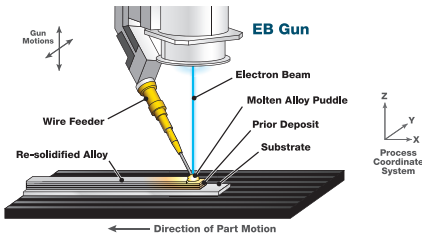

**The best material candidates for EBAM applications are weldable metals that are available in wire feedstock. Includes:**

- ▶ Titanium and Titanium Alloys
- ▶ Inconel 718, 625
- ▶ Tantalum
- ▶ Tungsten
- ▶ Niobium
- ▶ 2319/4043 Aluminum
- ▶ 70/30 Copper Nickel
- ▶ 4130/4135 Steel
- ▶ Stainless Steel (300 Series)

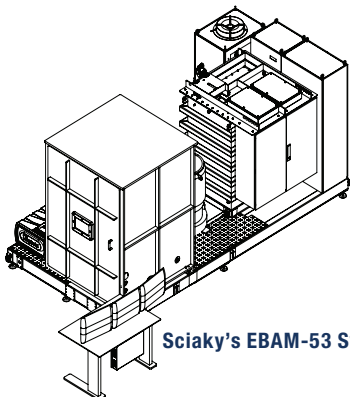

Sciaky's EBAM-53 System

## Metal Additive Manufacturing | 3D Printing Do It All With The EBAM<sup>®</sup>-53

The EBAM-53 is the ideal platform for materials research laboratory settings. This system has a smaller space requirement and lower cost, but features all of the same Electron Beam Additive Manufacturing advantages as the larger scale EBAM systems. The EBAM-53 will fit into your laboratory, enabling process optimization and materials development. Because the same EBAM equipment is used, your research will be directly scalable into the larger production-ready EBAM models. Contact Sciaky to discuss how we can help your research and pre-production activities without the floor space and capital expense requirements of full-scale EBAM systems.

### SCI AKY'S EBAM-53 SYSTEM TECHNICAL DATA:

- ▶ Chamber Dimensions: 53" (1346 mm) x 53" (1346 mm) x 72" (1880 mm)
- ▶ Build Envelope: 26" (635mm) wide x 26" (635 mm) deep x 26" (635 mm) high
- ▶ High Efficiency Pumping (up to  $1 \times 10^{-5}$  Torr ultimate vacuum pressure)
- ▶ Power Level up to 42 kW–60 kV
- ▶ Internal Boom Mounted Gun with High Resolution Optics & Servo Gun Tilt Axis
- ▶ X, Y & Z Servo Axes with Multiple Part Positioner Options
- ▶ CNC Control: Joint Scanning and Digitizing System
- ▶ Wirefeed with Motorized Wire Nozzle - Dual wirefeed optional
- ▶ Electron Beam Additive Manufacturing (EBAM<sup>®</sup>) Package with IRISS<sup>®</sup> Closed-Loop Control (CLC)

### SCI AKY'S EBAM-53 UTILITIES:

- ▶ Electrical Supply Option 1: 480 VAC, 3 PH, 100 Amp, 60 Hz
- ▶ Electrical Supply Option 2: 400 VAC, 3 PH, 100 Amp, 50/60 Hz
- ▶ Custom Electrical Supply Options Available
- ▶ Air Supply: 90 PSIG (6.3 Kg/cm<sup>2</sup>), 130 psi max, 15 SCFM (26 CMH) nominal
- ▶ Water: 35 PSIG (2.5 Kg/cm<sup>2</sup>), 60°F (16°C), 13.5 GPM (51 L/M)
- ▶ Chiller: 400-480 VAC, 3 PH, 40 Amp, 50/60 Hz Option

To learn about Sciaky's patented technology, visit [www.sciaky.com/patents](http://www.sciaky.com/patents)

1+(877)450-2518 | [sciaky.com](http://sciaky.com)

## ► SCIAKY'S ELECTRON BEAM ADDITIVE MANUFACTURING (EBAM) TECHNOLOGY: HOW DOES IT WORK?

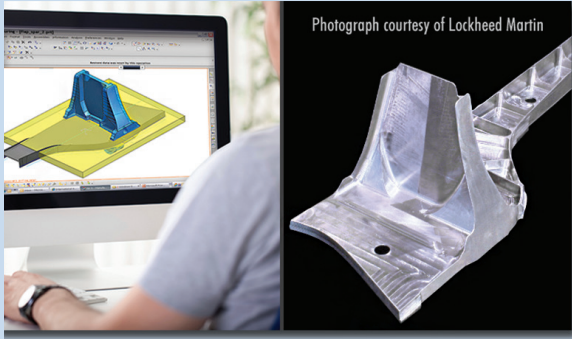

Starting with a 3D model from a CAD program, Sciaky's fully-articulated, moving electron beam gun deposits metal (via wire feedstock), layer by layer, until the part is built and ready for finish machining. Deposition rates typically range from 5 to 25 lbs/hr (2.27 to 11.36 kg/hr), depending upon part geometry and the material selected.

The EBAM package provides a precisely controlled beam geometry that produces superior energy distribution on the melt pool and wire for great repeatable performance. Requiring very little maintenance, the EBAM filaments can be changed out in 10 minutes at the end or beginning of any chamber cycle.

## ► PARTS CREATED WITH SCIAKY'S ELECTRON BEAM ADDITIVE MANUFACTURING (EBAM) TECHNOLOGY:



## ► IRISS® CLOSED-LOOP CONTROL TECHNOLOGY PROVIDES REAL-TIME ADAPTIVE CONTROL

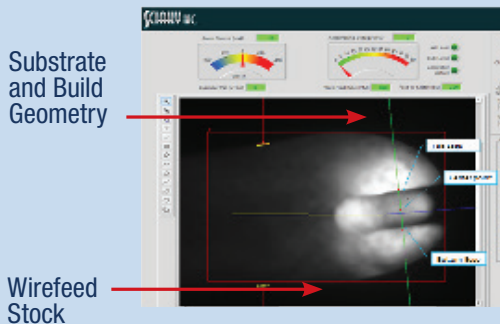

IRISS is a patented suite of sensors, software logic, and CNC controls that monitors key metal deposition parameters in order to make real-time adjustments to the deposition inputs. The data collected from the process is quantified and digested by our IRISS software algorithms. The outputs from the software will change deposition parameters such as EB power, wire feed rate, and CNC motion profiles. These adjustments are made dozens of times per second in order to guarantee that every ounce or gram of metal deposited experiences the same transition from wire, to liquid, to solid. The result is a consistent production of high quality parts, from the first part to the last.

**To learn more about Sciaky's Electron Beam Additive Manufacturing (EBAM) Technology, call us at 1-877-450-2518, or visit [sciaky.com](http://sciaky.com).**